

Fiber Optic Cable Transmission

**Silica Clad Silica
(1m length fiber optic cable)**

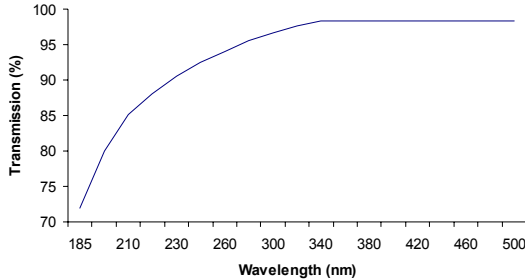

**Plastic Clad Silica
(1m length fiber optic cable)**

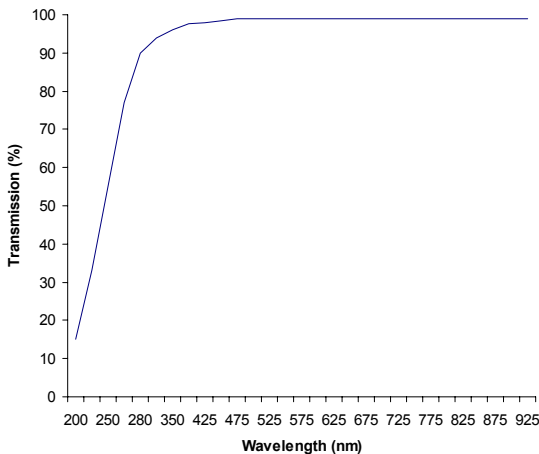

Borosilicate Glass

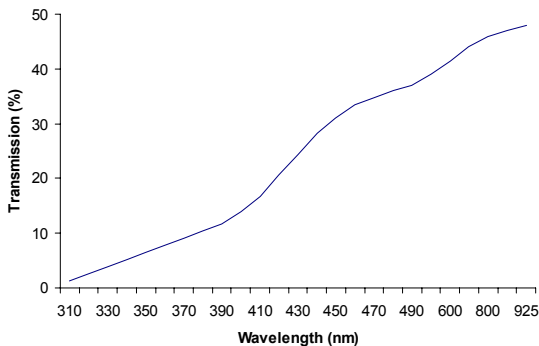

Silica Clad Silica/Deep UV

For UV applications, the best transmission is through silica clad silica fibers. This fiber carries the “DUV” designation as part of the Verity model number.

General:	For use above 185nm
Operating Temperature:	To 100°C
Bend Radius:	2.6 (6.6cm)
Packaging:	Fused Silica Core Doped Silica Cladding Polymide Jacket

Plastic Clad Silica/UV

Plastic clad silica fiber falls off sharply below 300nm. This fiber carries the “UV” designation as part of the Verity model number.

General:	For use above 300nm
Operating Temperature:	To 100°C
Bend Radius:	0.8 (2.0cm)
Packaging:	Fused Silica Core Polymer Cladding Acrylate Jacket

Borosilicate Glass

Glass fiber optic cable is the least costly, but should not be used in applications below 400nm. Additionally, glass bundles are fundamentally limited in length, even in favorable wavelength regions. For example, the maximum transmission of a 5' (1.5m) long bundle is less than 50 percent even at its most favorable wavelength. This type of fiber optic cable carries the “V” designation as part of the Verity model number.

Fiber Optic Cables – Non-Bifurcated

SPOT-TO-SPOT END TREATMENTS – EP200

Use with PM225 detector and EP200 Series monochromators. When using the Series monochromator, be sure to select the EP200FOC instrument coupler.

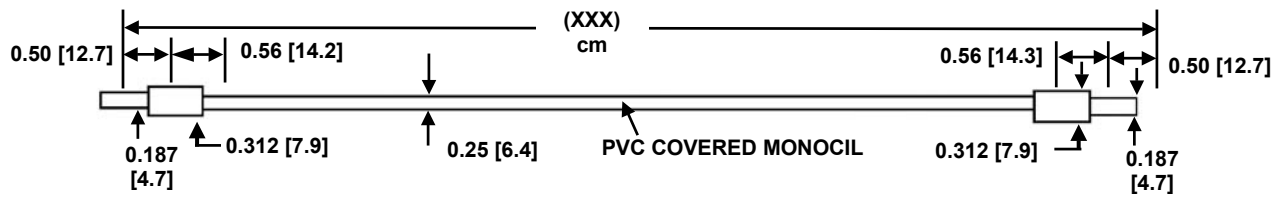

Type of Material	Description	Model Number	Part Number
Plastic Clad Silica Fibers – 0.125 (3.2mm) dia. bundle	12" (30cm)	FO-UV8-12	1001790
	24" (61cm)	FO-UV8-24	1001791
	36" (91cm)	FO-UV8-36	1001792
	60" (152cm)	FO-UV8-60	1001793

SPOT-TO-SLIT END TREATMENTS –

Use with all EP Series monochromators. Be sure to select the EP200SCR instrument coupler.

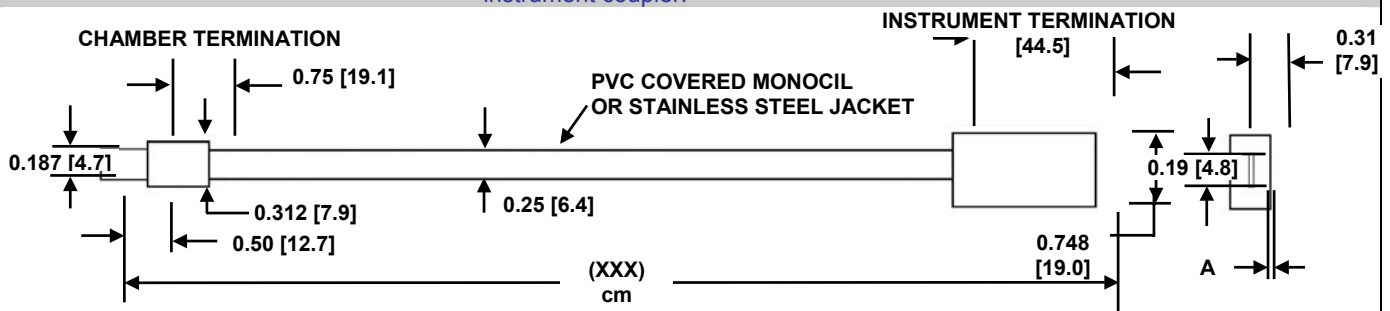

Type of Material	Description	PVC Covered Monocoil		Stainless Steel Jacket	
		Model Number	Part Number	Model Number	Part Number
Borosilicate Glass Fibers, 1.0mm width	50 cm	SL-V10-050	1002898	SLX-V10-050	Consult factory
	100 cm	SL-V10-100	1002899	SLX-V10-100	Consult factory
	200 cm	SL-V10-200	1002633	SLX-V10-200	Consult factory
Plastic Clad Silica Fibers, 1.0mm width	50 cm	SL-UV10-050	1001770	SLX-UV10-050	Consult factory
	100 cm	SL-UV10-100	1001641	SLX-UV10-100	Consult factory
	200 cm	SL-UV10-200	1001799	SLX-UV10-200	1002542
Silica Clad Silica Fibers, 0.5mm width	50 cm	SL-DUV05-050	1001797	SLX-DUV05-050	Consult factory
	100 cm	SL-DUV05-100	1001798	SLX-DUV05-100	1002413
	152 cm	SL-DUV05-152	1001634	SLX-DUV05-152	Consult factory
	200 cm	SL-DUV05-200	1002276	SLX-DUV05-200	1001633
	250 cm	SL-DUV05-250	1002867	SLX-DUV05-250	1001632
Silica Clad Silica Fibers, 1.0mm width	50 cm	SL-DUV10-050	1001794	SLX-DUV10-050	Consult factory
	100 cm	SL-DUV10-100	1001795	SLX-DUV10-100	1002045
	200 cm	SL-DUV10-200	1001796	SLX-DUV10-200	1002879

Fiber Optic Cables – Bifurcated

Type	Glass	Silica	Silica
Covering	PVC Covered Monocoil	Stainless Steel	PVC Covered Monocoil
Source End [inches (mm)]	0.11 (2.7) SPOT 0.187 (4.7) O.D.	0.02 (0.5) SPOT 0.187 (4.7) O.D.	0.10 (2.5) SPOT 0.187 (4.7) O.D.
Instrument End (2) [inches (mm)]	0.02 (0.5) x 0.2 (5.0) SLIT 0.312 (7.9) x 0.748 (19.0)	0.02 (0.5) x 0.2 (5.0) SLIT 0.312 (7.9) x 0.748 (19.0)	0.02 (0.5) x 0.2 (5.0) SLIT 0.312 (7.9) x 0.748 (19.0)
Length [inches (cm)]	72 (183) Split 32 (133) from source	78 (200) Split 58 (150) from source	39 (100) Split 19.5 (50) from source
Model No.	BSL-V05-133-50	SLX-DUV05-150-2/50	BSL-DUV05-50-50
Part No.	1002700	1001404	1001810
Use With	All EP Series monochromators with the proper coupler. Use EP200FOC for spot termination and EP200SCR for slit terminations.		

Chamber-Mounted Vacuum Feedthroughs

When using the vacuum feedthrough system, insert the fiber optic cable into the right side of the vacuum feedthrough (as shown below), through the flexible tube, and into the optical head. Three M2.5 screws can be used to support the optical head.

The chamber-mounted vacuum feedthrough system is designed for applications where a window or viewport is expected to become coated from the process, or if a feedthrough system provides better viewing of the plasma. In applications where a feedthrough is selected because of deposition considerations, use the OC/OCH-208 optical head since it includes a capillary cartridge designed to minimize contamination of the viewing lens. In applications where the feedthrough system is used to provide better plasma viewing and if deposition is not deemed to be an issue, use the OC/OCH-207 optical head. The OC/OCH-207 is the same as the OC/OCH-208, except that it does not include a capillary cartridge.

Each chamber mounted vacuum feedthrough should include three items:

- Vacuum Feedthrough
- Flexible Tube
- Optical Head

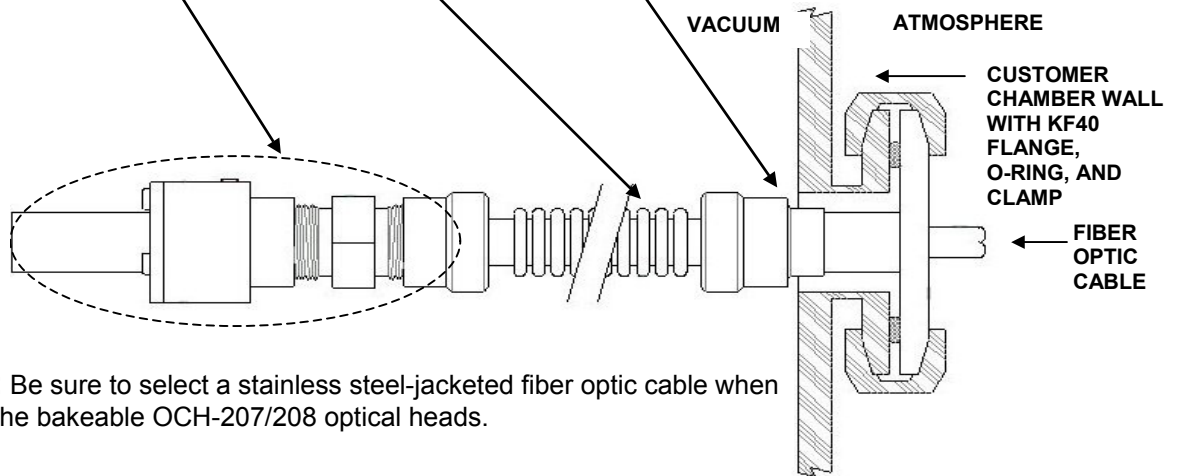

Note: Be sure to select a stainless steel-jacketed fiber optic cable when using the bakeable OCH-207/208 optical heads.

VACUUM FEEDTHROUGHS – Three types of vacuum feedthroughs are available. This includes KF25 adapter, a KF40 adapter, and a 1" (25.4mm) dia. hole adapter.

- KF25 Flange with integral 0.375" (9.5mm) UltraTorr® fitting
- KF40 Flange with integral 0.375" (9.5mm) UltraTorr® fitting

Description	Model No.	Part No.
KF25 x 0.375" UltraTorr®	FOF-KF25	1001774
KF40 x 0.375" UltraTorr®	FOF-KF40	1001598

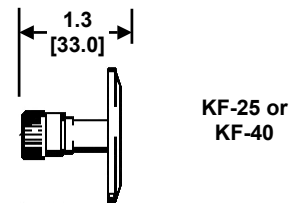

- 1" (25.4mm) dia. hole x 0.375" (9.5mm) UltraTorr® fitting

Description	Model No.	Part No.
1" (25.4mm) dia. Hole x 0.375" UltraTorr®	FOF-1.0	1001773

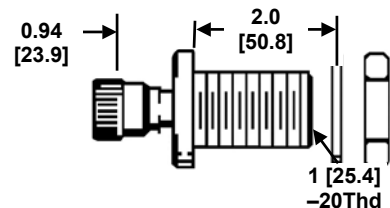

Continued on the next page...

FLEXIBLE TUBE – The flexible tube couples the vacuum feedthrough to the optical head. Each flexible tube comes with a pair of XOA end adapters.

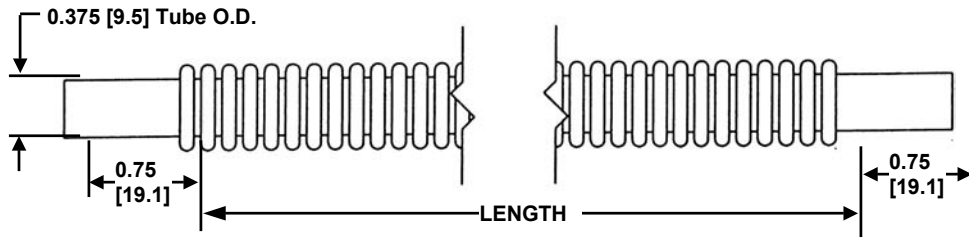

Length (Bellows) [inches (mm)]	Model No.	Part No.	Maximum Length [inches (mm)]	Minimum Length [inches (mm)]	Angular Displacement (degrees)
1 (25.4)	VFT-01	1000473-100	1.5 (38.1)	0.75 (19.1)	90
3 (76.2)	VFT-03	1000473-101	4.5 (114.3)	2.50 (63.5)	225
6 (152.4)	VFT-06	1000473-102	9.0 (228.6)	4.75 (120.7)	360
12 (304.8)	VFT-12	1000473-103	18.0 (457.2)	9.00 (228.6)	360
24 (609.6)	VFT-24	1000473-104	36.0 (914.4)	18.00 (457.2)	360

OPTICAL HEAD – The optical head includes a sight tube with an optional capillary cartridge installed within it. The capillary cartridge is an array of small diameter (50 microns) stainless steel tubes with a high aspect ratio (length to diameter) that impedes deposition from reaching the lens surface. A lens focuses source light into the fiber optic cable. When provided with Kalrez® O-rings (OHC models), the optical head permits baking to 300°C, while the Viton® O-rings (OC models) permit baking to 150°C.

(3) M2.5 SCREWS ON 0.7 (17.8) DIA. B.C. (MOUNTING BRACKET NOT INCLUDED)

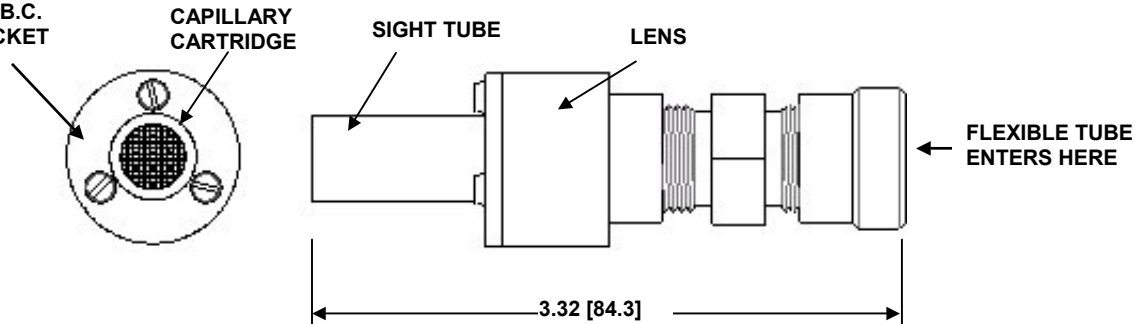

Description	Model No.	Part No.
150°C	OC-207	1001669
150°C, capillary cartridge	OC-208	1001693
300°C	OCH-207	1001687
300°C, capillary cartridge	OCH-208	1001695

OPTICAL HEAD – SPARE PARTS

Description	Model No.	Part No.	Details (Use with)
Replacement Silica Lens – Bi-Convex	1000545	OC/OCH-205/206
Replacement Silica Lens – Plano-Convex	SL-1	1001679	OC/OCH-207/208
Replacement Kalrez® O-Ring, K102	AS-568A	1000342	205/206/207/208 (2 required)
Replacement Viton® O-Ring	1001134	205/206/207/208 (2 required)
Replacement Capillary Cartridge	CC-1	1001478	OC/OCH-205/206/207/208

205/206 Upgrade to 207/208 – In dim light applications, it may be desirable to upgrade from the OC/OCH-205/206 to the OC/OCH 207/208. The plano-convex lens of the 207/206 is about twice as efficient as the 205/206's bi-convex lens. Since the 207/208 assembly is only 0.06" (1.5mm) shorter than the 205/206, the placement on the flexible tube assembly easily accommodates the difference.

Chamber-Mounted Optical Couplers (Non-Vacuum Feedthrough Types)

Description	Model Number	Part Number
FOCUSING LIGHT COUPLER	LC10	1001859

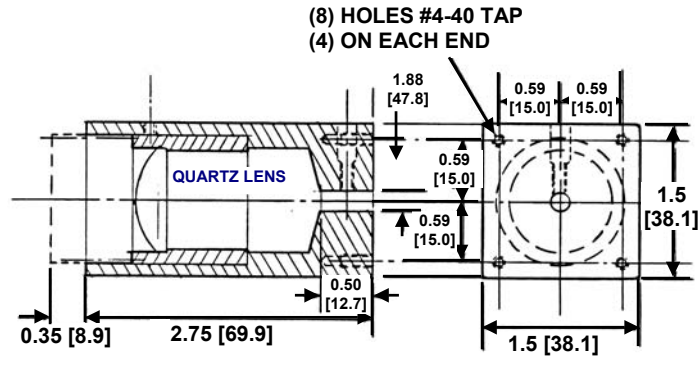

- 0.187" (4.7mm) dia. fiber optic cable to 1" (25.4mm) quartz lens
- Focuses from 4.28" (108.7mm) to infinity
- Transmits UV, VIS, and NIR

Description	Model Number	Part Number
RIGHT ANGLE LIGHT COUPLER	EP200PAC	1000447

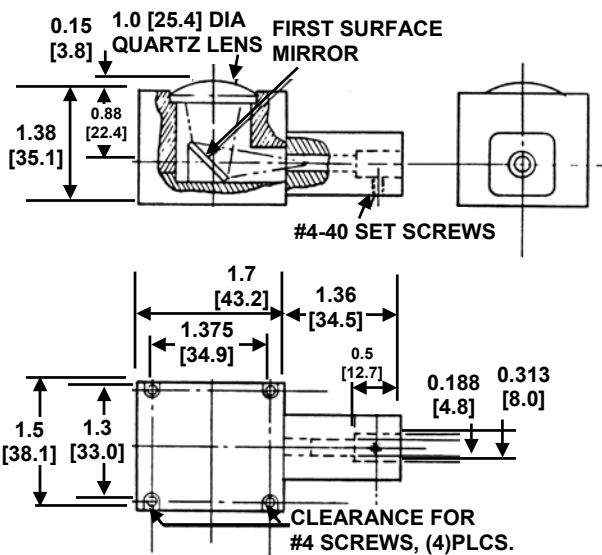

- 0.187 in (4.7mm) dia. fiber optic cable to 1" (25.4mm) quartz lens
- Transmits UV, VIS, and IR
- Focuses on a point 135mm from the lens. At 1m from the lens, the viewing area is a circle with a diameter of 300mm.

This coupler mounts on a chamber next to a viewport and transmits UV, VIS, and NIR. It provides a means for coupling light into a fiber optics bundle in a compact configuration at a right angle to the viewing axis.

Description	Model Number	Part Number
FOCUSING LIGHT COUPLER, KF40 FLANGE	LC-KF40V	1002561

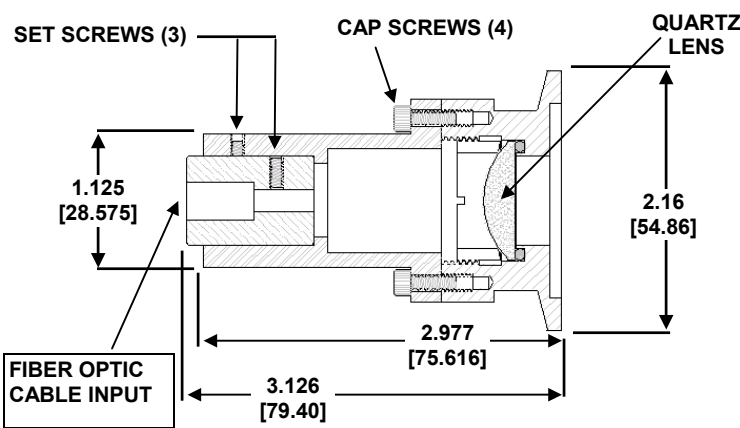

- 0.187" (4.7mm) dia. fiber optic cable to KF40 vacum flange
- 1" (25.4mm) quartz lens
- Transmits UV, VIS, NIR
- Focuses collimated and near collimated light to the fiber optic cable